

深圳百问网科技有限公司 https://100ask.taobao.com			
Title: 百问_IMX6ULL_STD底板原理图			
Size: A3	Page Name: <Doc>	Rev: ?	
Date: Sunday, December 15, 2019	Sheet: 1	of: 12	1

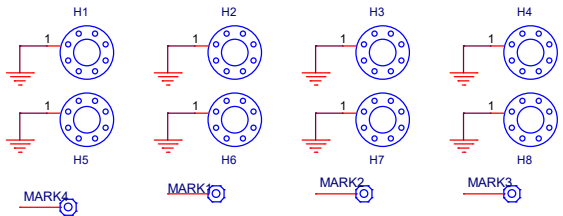

12V Power input

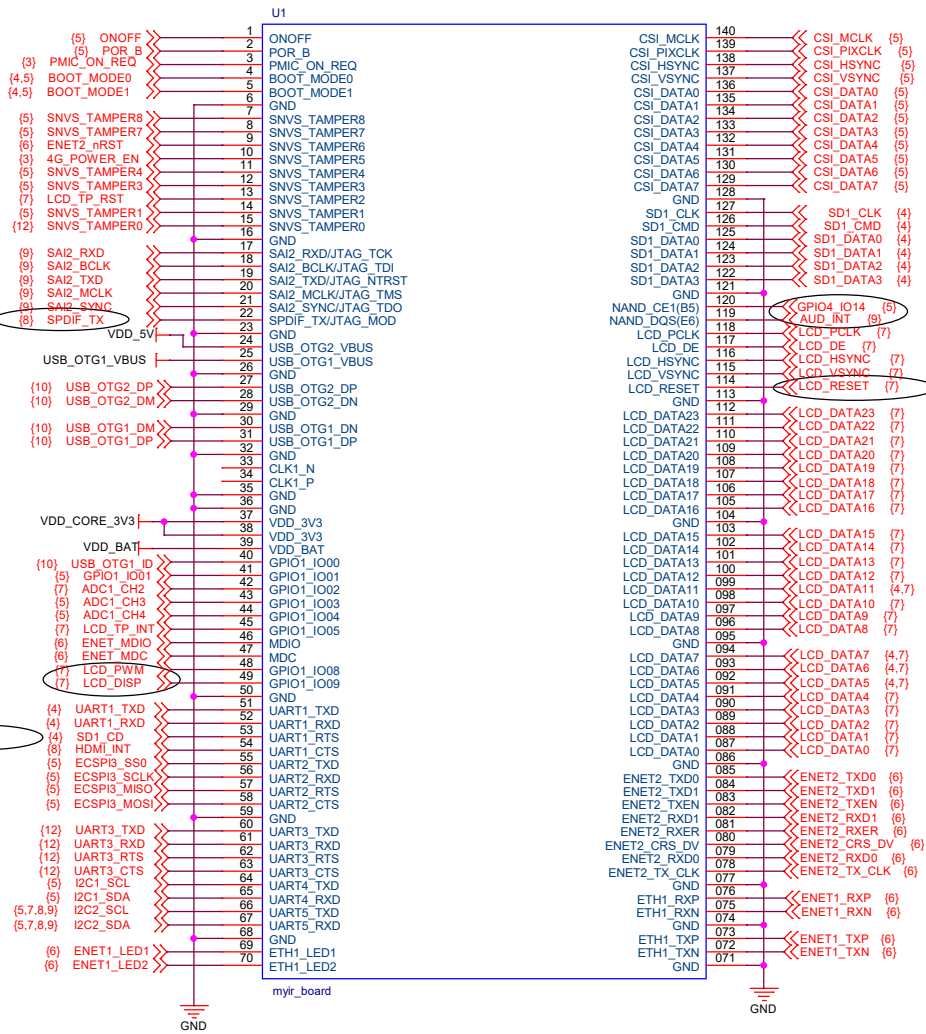
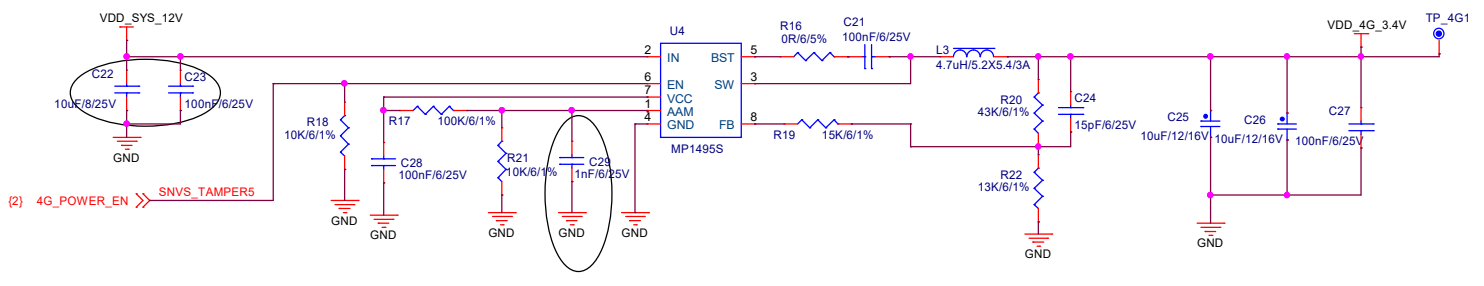
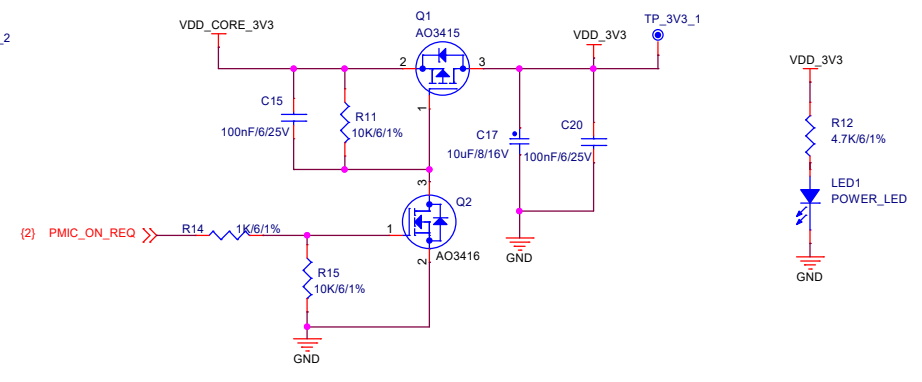
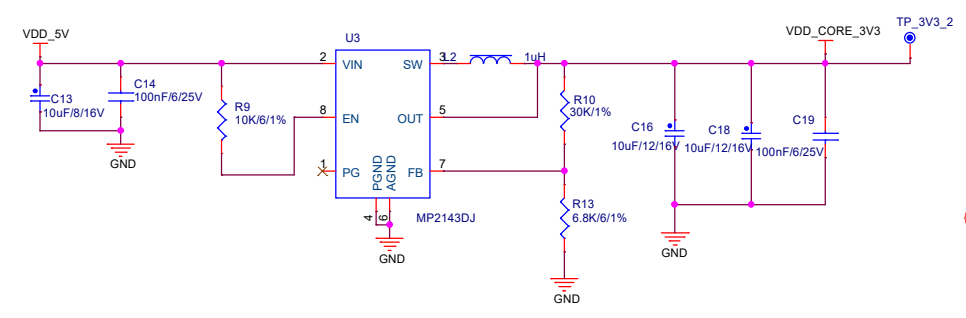
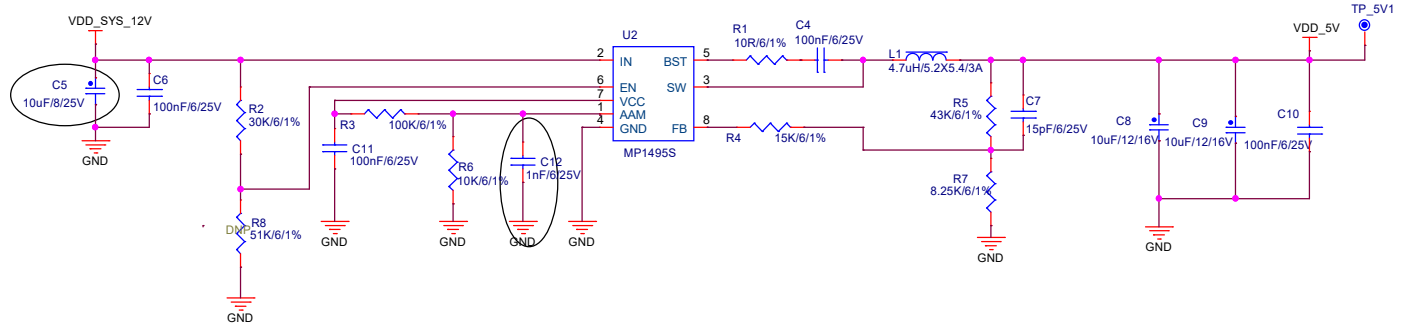
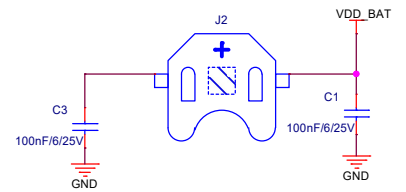
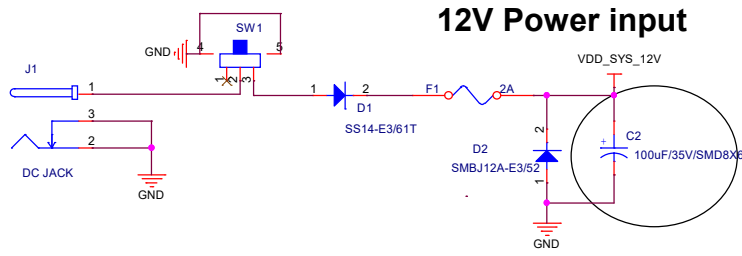

深圳百问网科技有限公司
<https://100ask.taobao.com>

Title: 百问_IMX6ULL_STD底板原理图

Size: A3	Page Name: <Doc>	Rev: ?
Date: Sunday, December 15, 2019	Sheet: 3	of 12

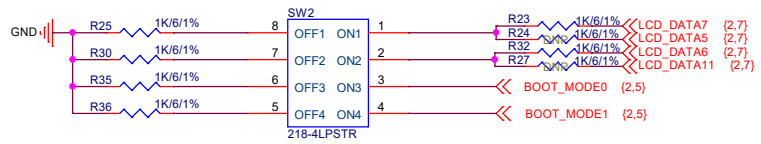

Boot Configure

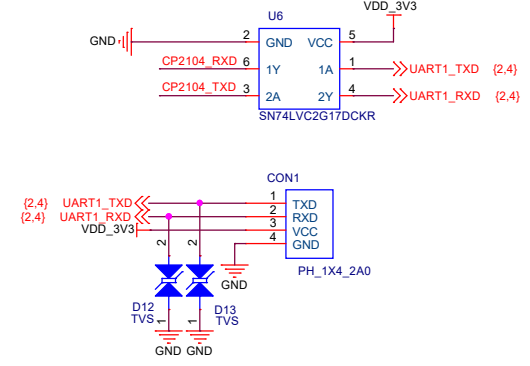
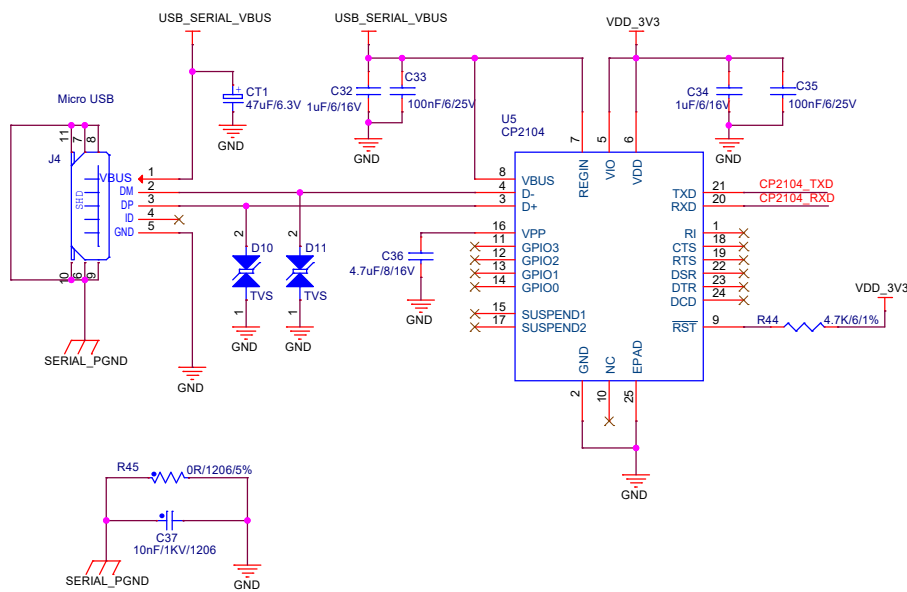
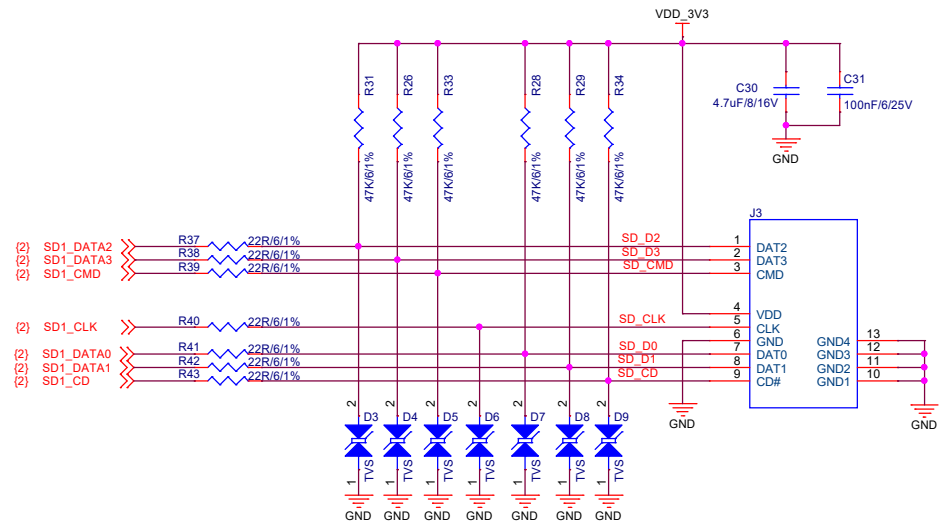

深圳百问网科技有限公司 https://100ask.taobao.com		
Title 百问_IMX6ULL_STD底板原理图		
Size A3	Page Name <Doc>	Rev ?
Date: Monday, December 16, 2019		Sheet 4 of 12

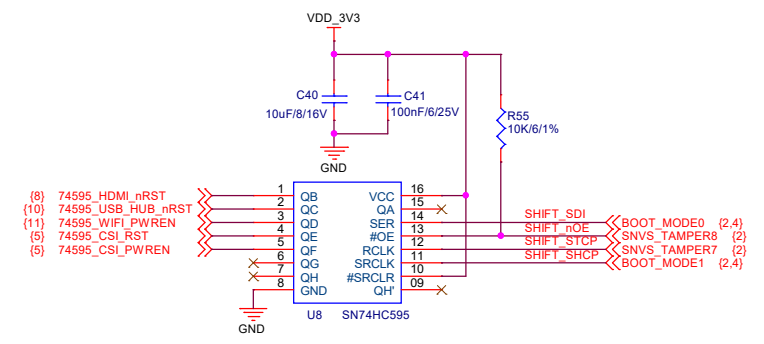
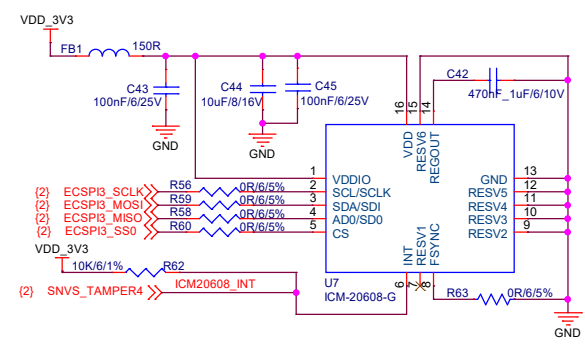
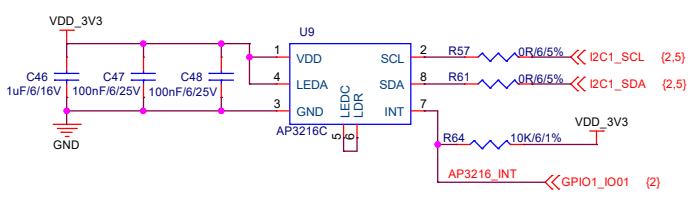
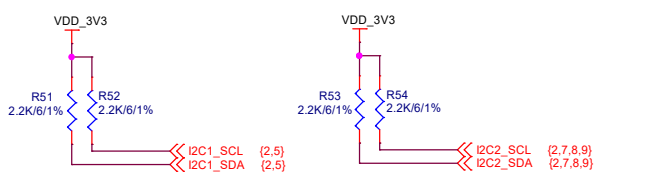
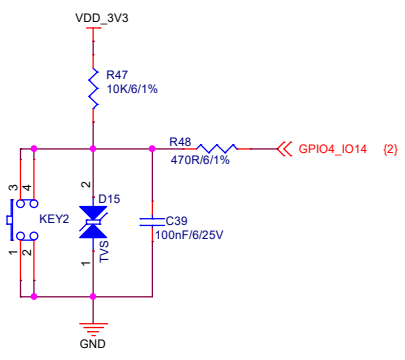
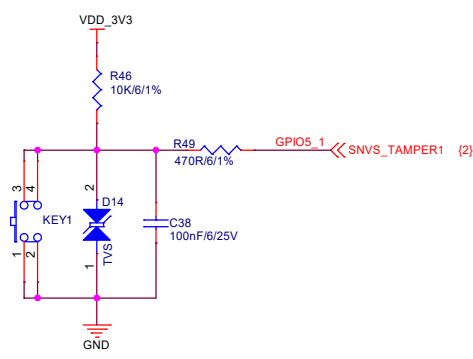
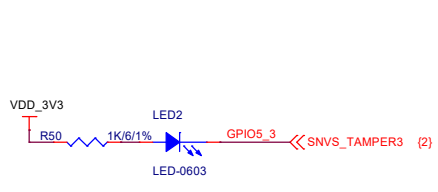

CAMERA

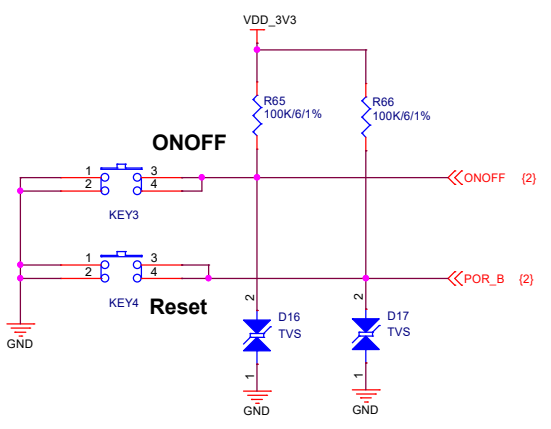
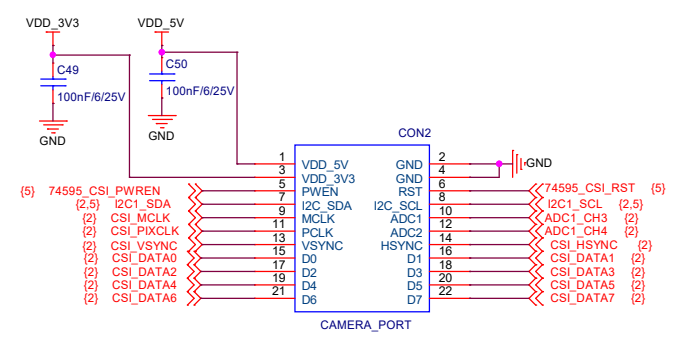

Ethernet 1

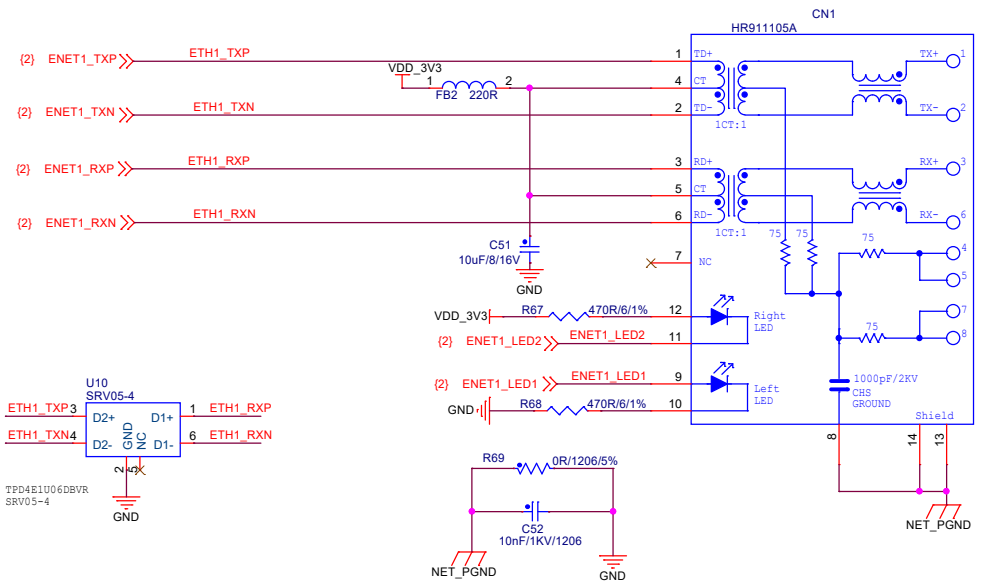

Ethernet 2

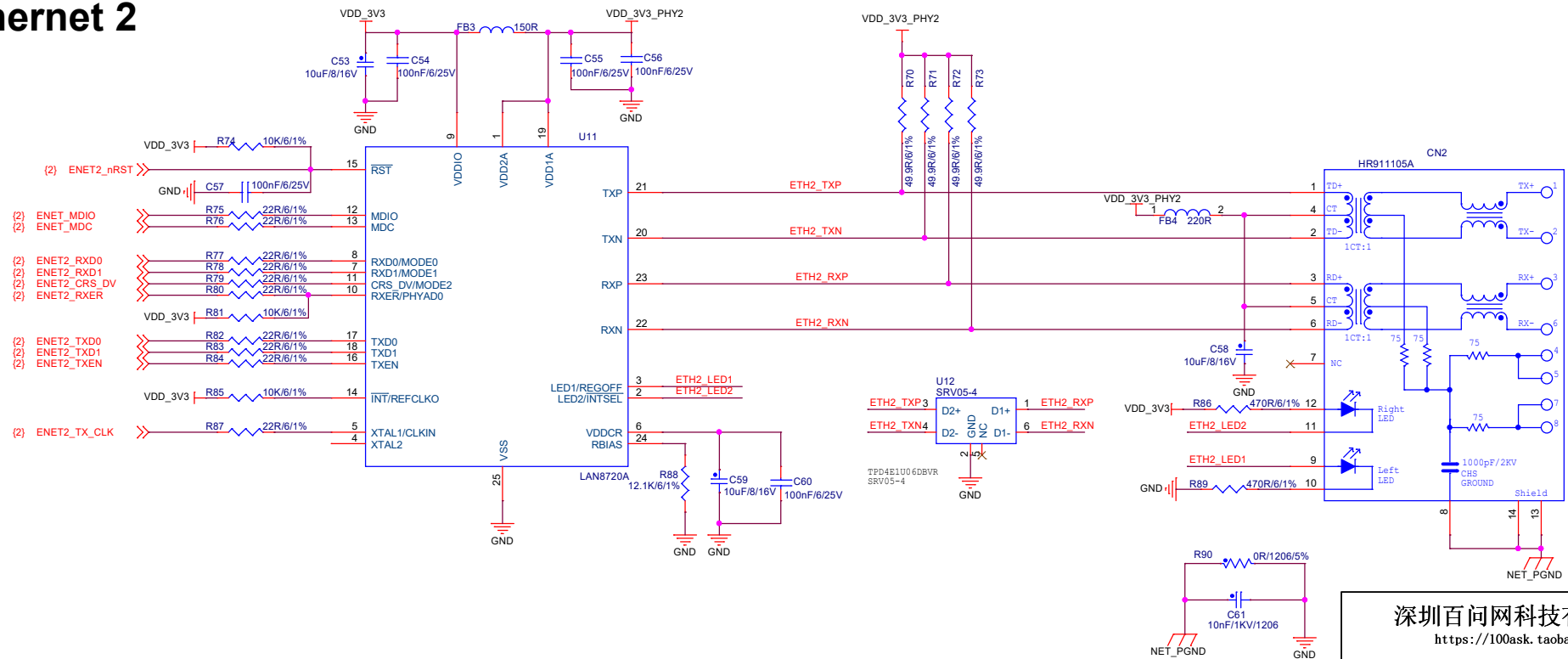

深圳百问网科技有限公司
<https://100ask.taobao.com>

Title		
百问_IMX6ULL_STD底板原理图		
Size	Page Name	Rev
A3	<Doc>	?
Date:	Monday, December 16, 2019	Sheet 6 of 12

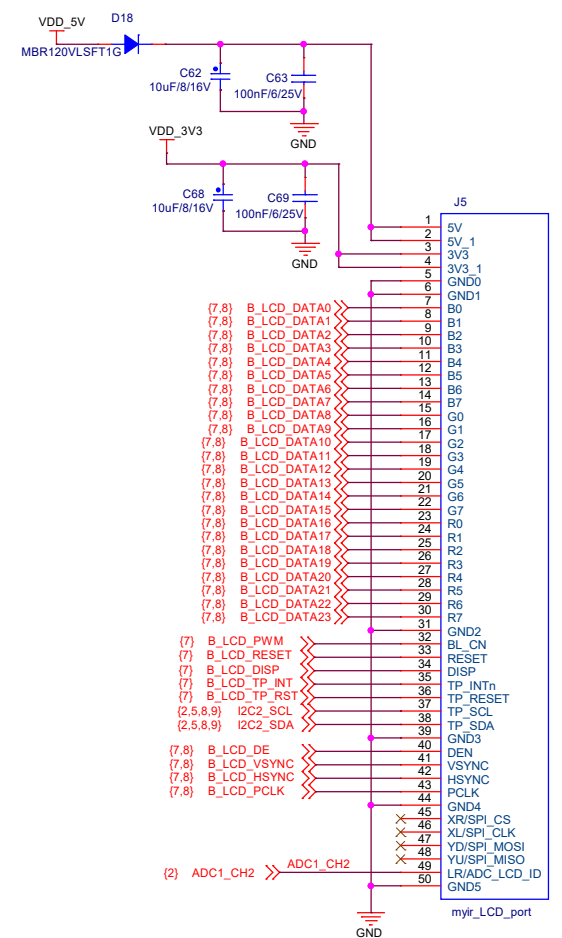
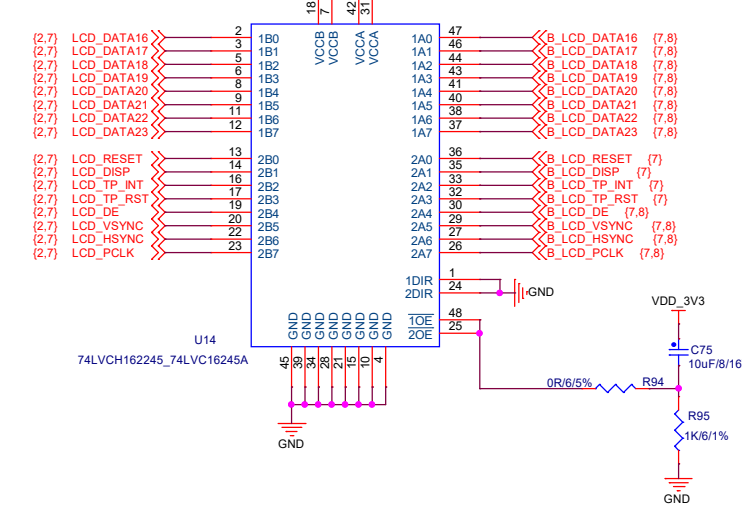
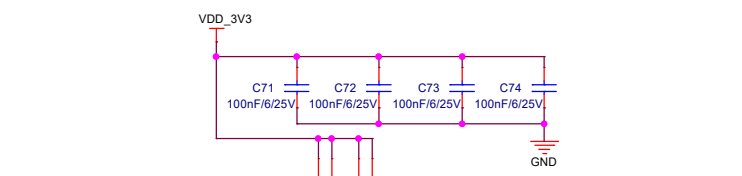
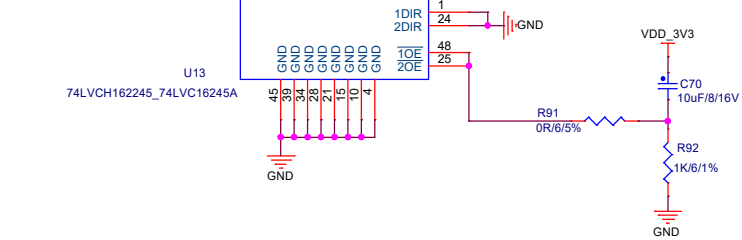
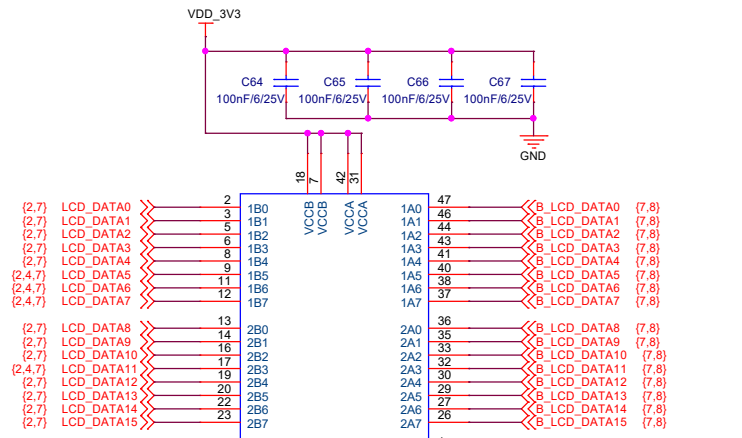
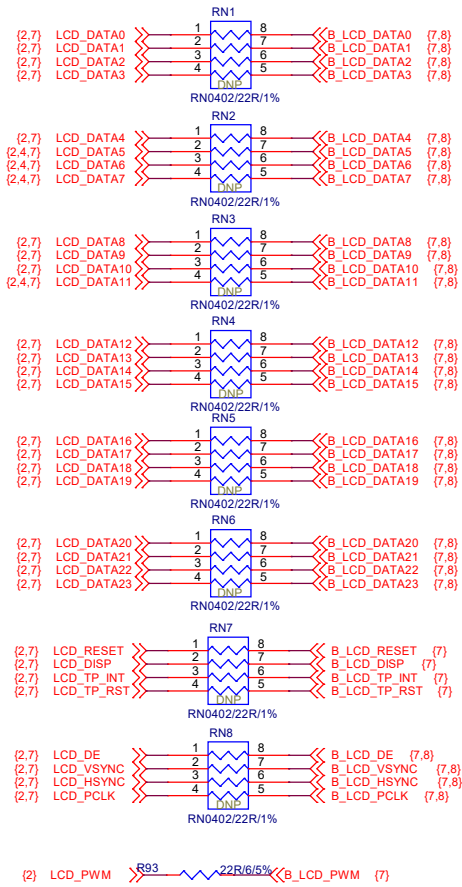

深圳百问网科技有限公司
 https://100ask.taobao.com

Title 百问_IMX6ULL_STD底板原理图

Size A3 Page Name <Doc> Rev ?

Date: Monday, December 16, 2019 Sheet 7 of 12

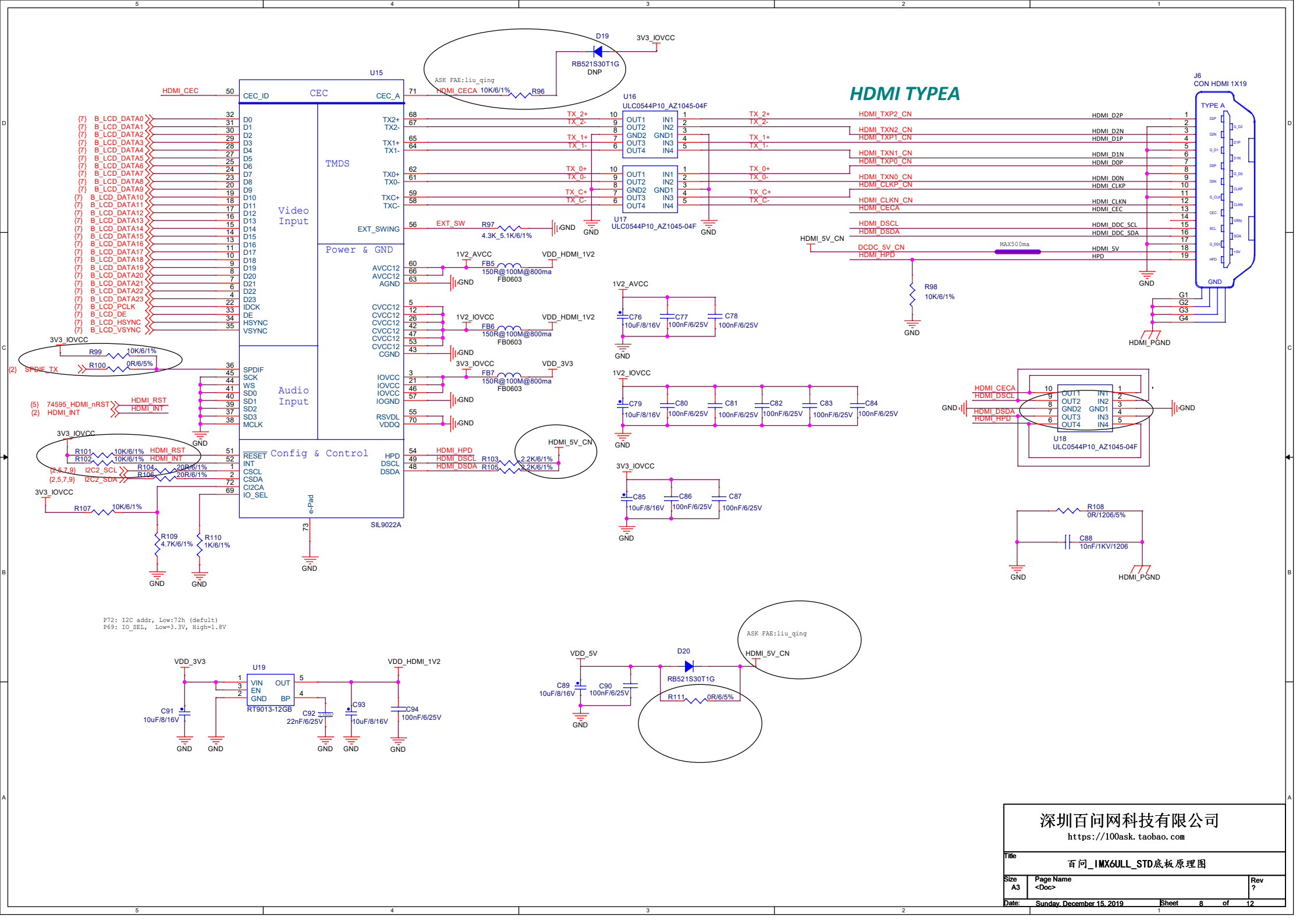

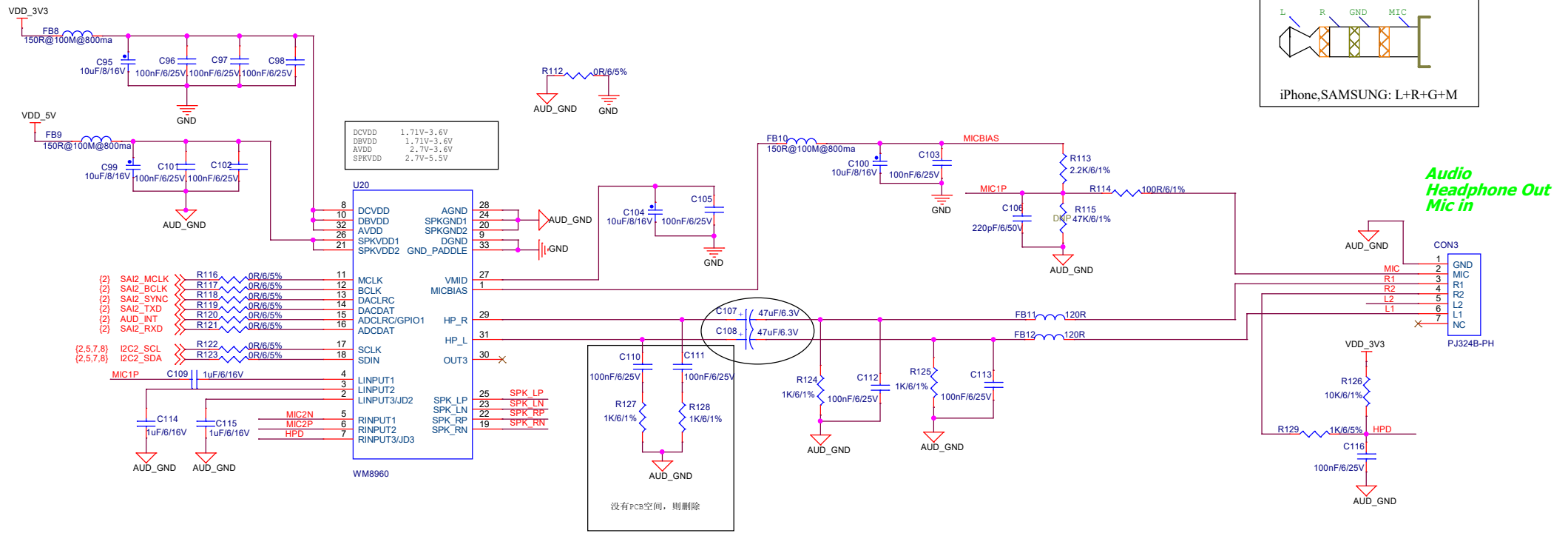

ECM AMIC

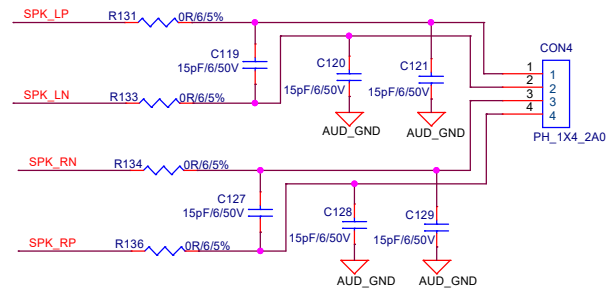
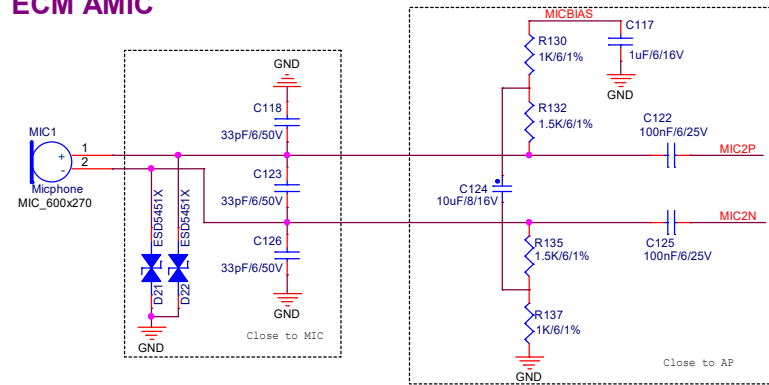

深圳百问网科技有限公司
<https://100ask.taobao.com>

Title		
百问_IMX6ULL_STD底板原理图		
Size	Page Name	Rev
A3	<Doc>	?
Date:	Monday, December 16, 2019	Sheet 9 of 12

USB-HUB

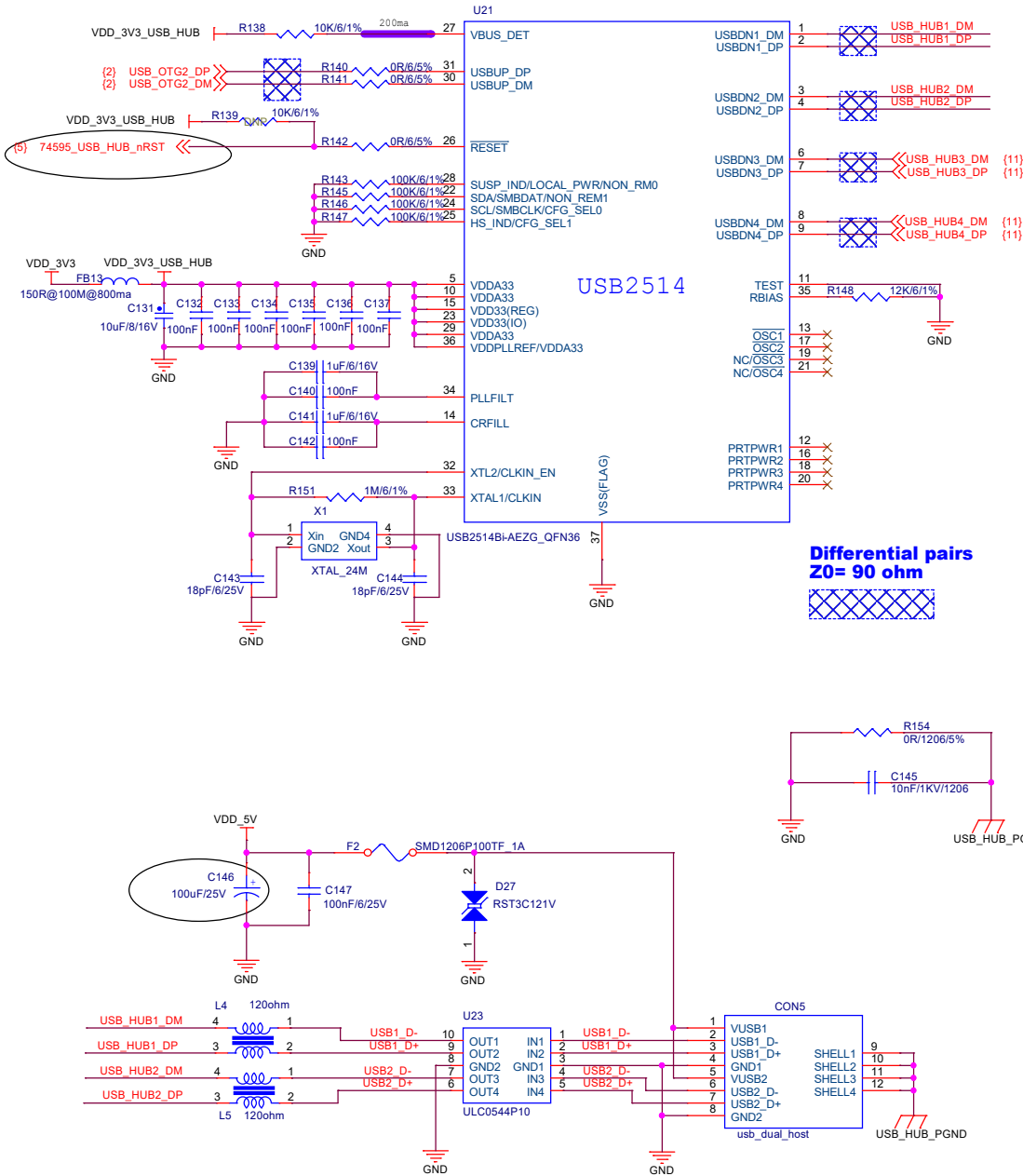

USB-OTG

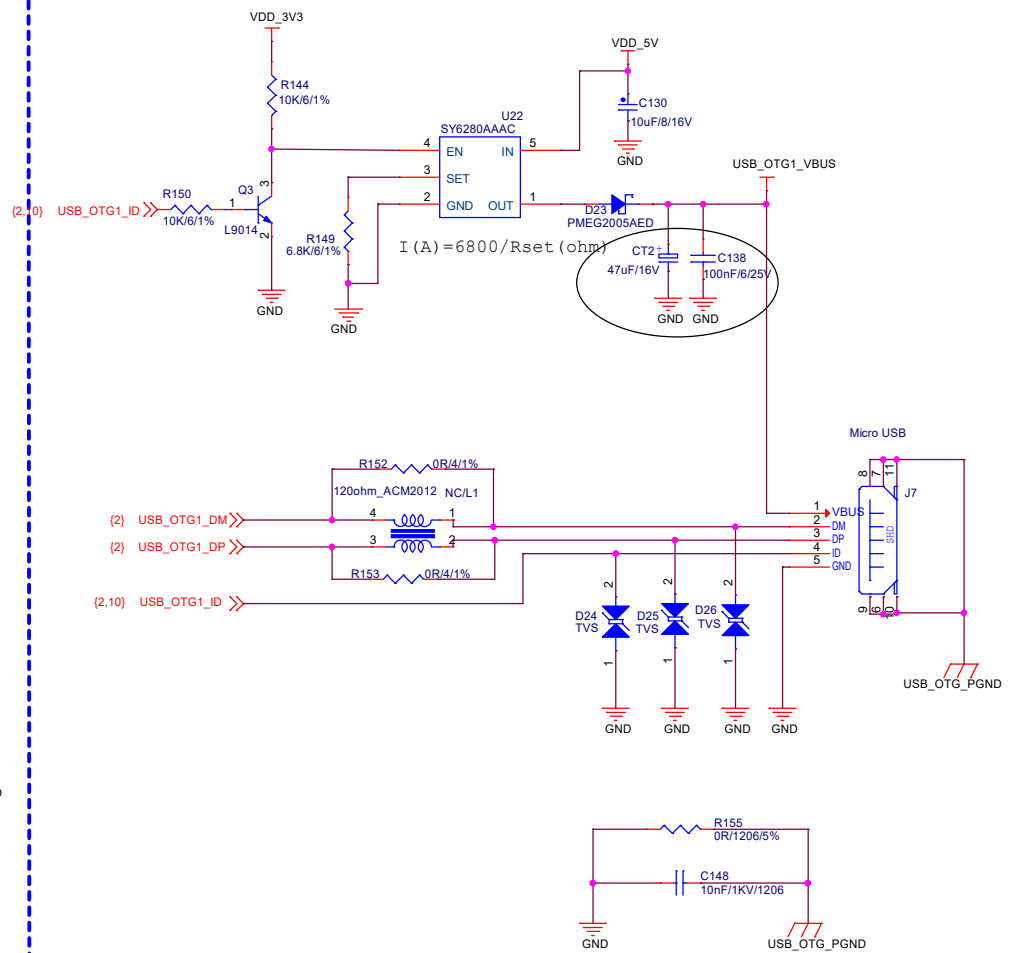

深圳百问网科技有限公司
<https://100ask.taobao.com>

Title: 百问_IMX6ULL_STD底板原理图

Size: A3	Page Name: <Doc>	Rev: ?
Date: Monday, December 16, 2019	Sheet: 10	of 12

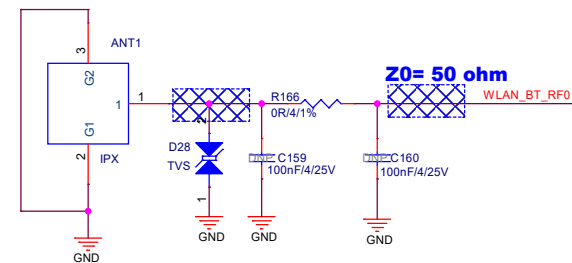
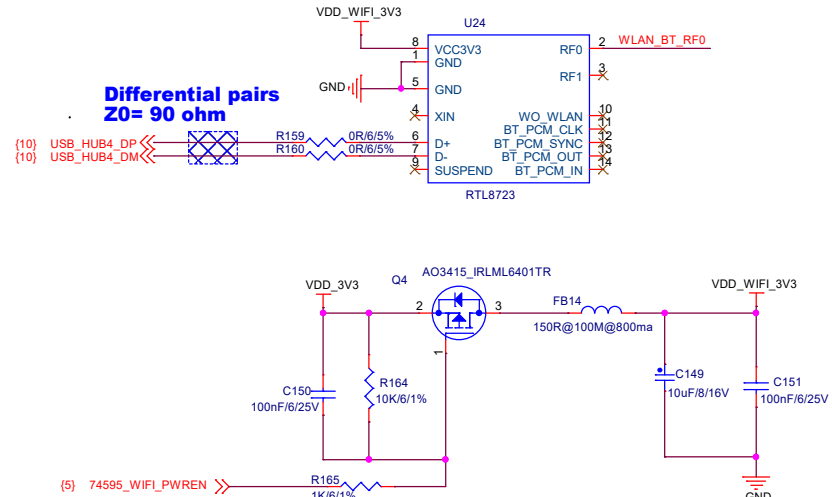
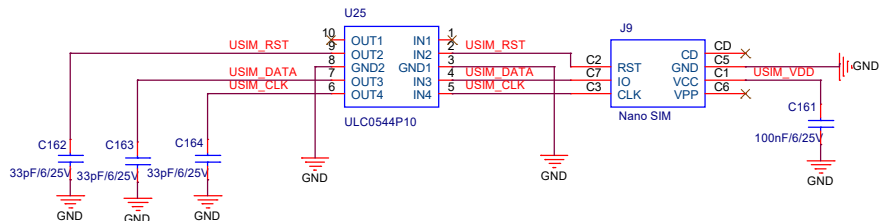
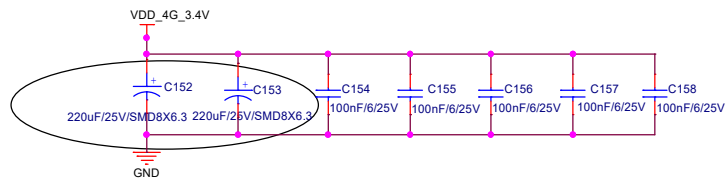
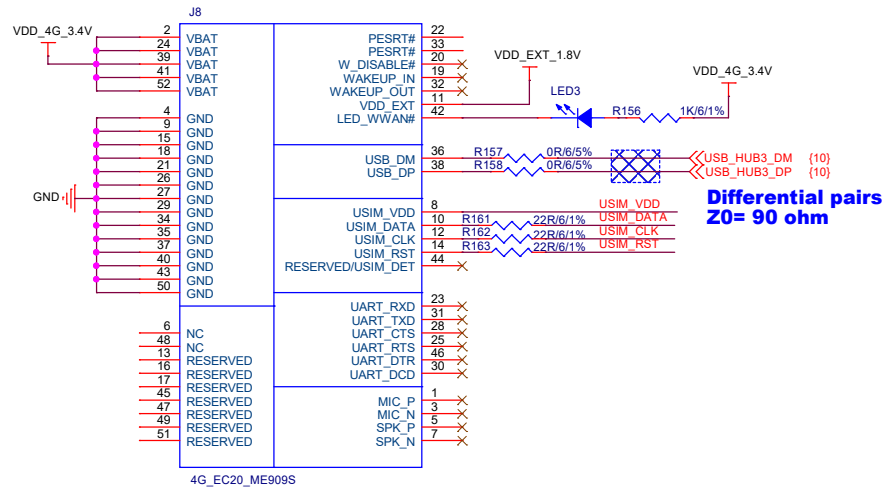

深圳百问网科技有限公司
https://100ask.taobao.com

Title: 百问_IMX6ULL_STD底板原理图		
Size: A3	Page Name: <Doc>	Rev: ?
Date: Monday, December 16, 2019	Sheet: 11	of 12

RS485

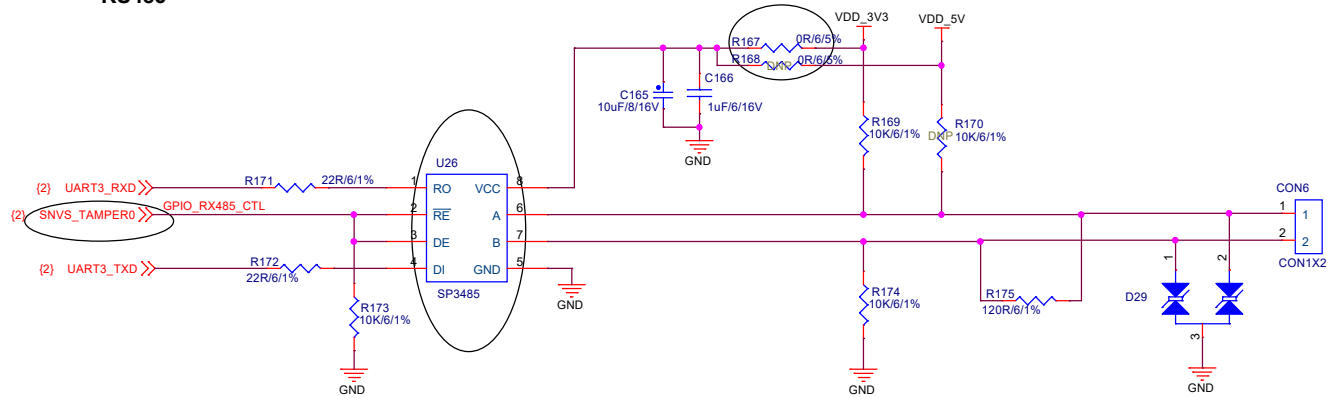

CAN

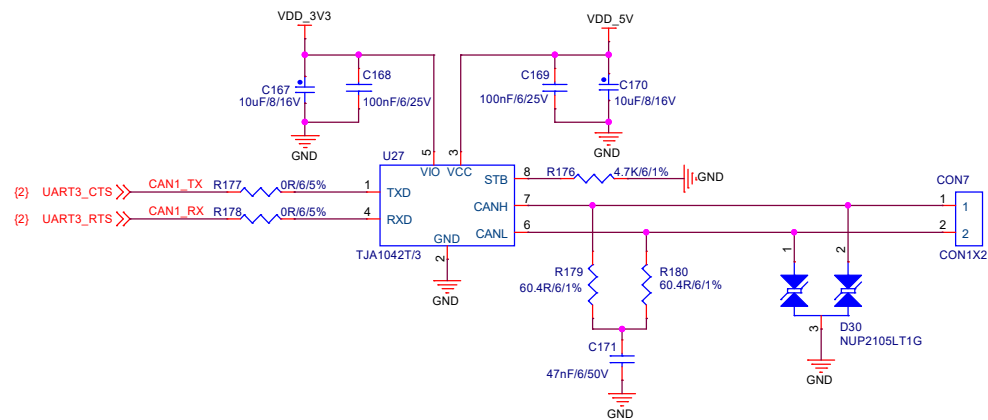

深圳百问网科技有限公司
<https://100ask.taobao.com>

Title		
百问_IMX6ULL_STD底板原理图		
Size	Page Name	Rev
A3	<Doc>	?
Date:	Monday, December 16, 2019	Sheet 12 of 12